



Horizontal Directional Drills

Application Notes



Fluid Power in Motion

Solutions for Horizontal Directional Drills.



Eaton has the products and capabilities to provide complete system solutions for your application needs. World class hydraulic components, electronic controllers and software are just part of the value Eaton brings to make your applications deliver the power, in fluid power. Tough applications require the experience and knowledge that Eaton can provide and this application information will help you get started. Contact your Eaton representative for further information or visit us on-line at www.hydraulics.eaton.com.



Types of Machines

There are a variety of different types of Horizontal Directional Drills (HDD).

HDD's are made in a variety of sizes and for various functions. Compact HDD's are made to operate in smaller areas to drill shallow wells. Some HDD's are designed to navigate rough terrain. The rough terrain includes solid rocky ground and broken rocky ground. Some HDD's are designed with high horsepower engines. These machines can pull over 1000 feet of pipe.

Performance Characteristics

The hydraulic system provides the performance that is required to operate a HDD. The HDD had to be able to have the power and speed to provide a high pipe rotation speed. The pipe speed and torque required are closely matched to provide the output performance required to keep the HDD engine operating at an optimum level. The pipe loader is hydraulically controlled. This control allows more pipe strands to be loaded and unloaded per hour to provide continual operation.

The hydraulic system provides a controlled torque that is high enough to break the toughest pipe connections. The four point anchoring system is hydraulically operated. The hydraulic control ensures that each of the anchors is securely anchored deep into the ground. The hydraulic power will ensure that the anchor is able to penetrate all types of ground conditions. The pipe carriage is a hydraulic operated two-speed system. The hydraulic system ensures that the carriage operates at optimum speeds.

The carriage runs at high speed when the pipe is being loaded and unloaded from the pipe rack. The carriage runs at a low speed high torque when the pipe is being thrust into the ground and when back reaming occurs.



General Circuit Notes

The drill is driven into place. The hydraulic tilt and stabilizers are set. The hydraulic anchor is driven into the ground. Pipe is loaded from the storage box onto the carriage. The wrenches grab the pipe and hold it while another set of wrenches join pipes together. The carriage thrusts the pipe into the ground. The mud motor drives the mud pump which forces drill fluid down the pipe in the hole. The carriage thrust pushes the pipe into the hole. The entire cycle is reversed when the hole is back reamed.

Circuit Design Considerations

- Use closed loop pump to perform the ground drive function and to drive the mud pump motor as an either/or circuit.
- Use four open loop disc valve in parallel or series to achieve the two-speed carriage function.
- Return oil used to super-charge the open loop piston pump
- Control the accumulator effect of the long run pipe so hydraulic spikes do not occur during pipe breakage

Hydraulic Functions

Functions typically driven and operated by the hydraulic system:

- Dual path ground drive
- Pipe clamp
- Pipe rotate
- Two speed carriage
- Pipe wrench
- Four point anchor
- Pipe thrust
- Mud pump drive
- Stabilizer
- Tilt
- Pipe lift
- Pipe grip
- Pipe loader
- Pipe Shuttle
- Grease pump drive
- Steering

Product families typically used for hydraulic systems

- Medium duty closed loop pump
- Open loop piston pump
- Open loop gear pump
- Filtration
- Cartridge valve
- Medium duty closed loop motor
- Cartridge valve manifold assembly
- Sectional lock directional control valve
- Open loop disc valve motor
- Open loop spool valve motor
- Open loop VIS motor
- Oil cooler
- Fluid conveyance

Basic formulae for sizing*

Pump Output Flow	$(\text{GPM}) = \text{RPM} \times \text{Displ (cid)} \times \text{Vol Eff} / 231$ $(\text{LPM}) = \text{RPM} \times \text{Displ (cc)} \times \text{Vol Eff} / 1000$
Pump Input Power	$(\text{HP}) = \text{GPM} \times \text{PSI} / (\text{Tot Eff} \times 1714)$ $(\text{KW}) = \text{LPM} \times \text{Bar} / (\text{Tot Eff} \times 598)$
Hydraulic Motor Speed	$\text{RPM} = \text{GPM} \times \text{Vol Eff} / (\text{Disp (cid)} \times 231)$ $\text{RPM} = \text{LPM} \times \text{Vol Eff} / (\text{Disp (cc)} \times 1000)$
Hydraulic Motor Torque	$(\text{inlb}) = \text{PSI (delta)} \times \text{Disp (cid)} \times \text{Mech Eff} / 6.283$ $(\text{N-m}) = \text{Bar (delta)} \times \text{Disp (cc)} \times \text{Mech Eff} / 62.83$
Cylinder Force	$(\text{lbs}) = \text{Area (square inches)} \times \text{PSI}$ $(\text{N}) = \text{Area (square mm)} \times \text{Bar} \times 10$
Cylinder Speed	$(\text{in/min}) = \text{GPM} \times 231 / \text{Area (square inches)}$ $(\text{mm/min}) = \text{LPM} \times 1000 / \text{Area (square mm)}$

Typical Circuits

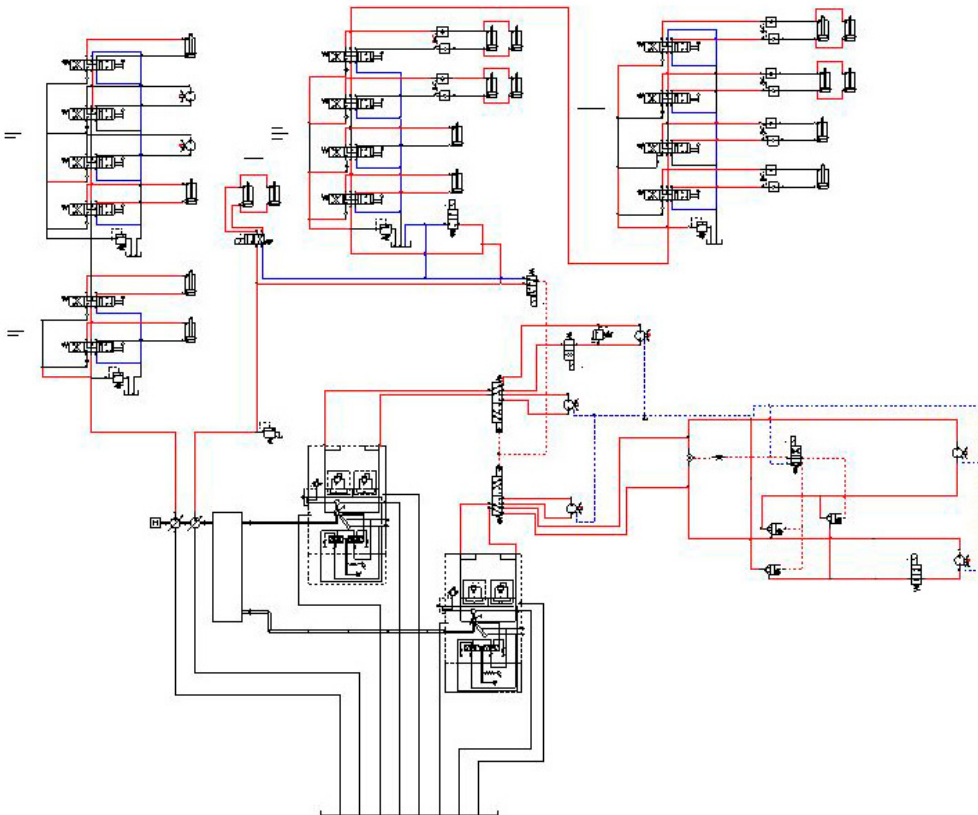

*** The following calculations may also need to be considered with regards to sizing:**

- Basic formulae are general in nature and do not take into account efficiency losses for individual components.
- System Hp calculations under all operating conditions
- Power range calculation
- Mechanical and volumetric efficiencies
- Product life
- Cooling capacity
- System pressure drop calculations
- Line flow velocity calculations

Eaton
Hydraulics Operations USA
14615 Lone Oak Road
Eden Prairie, MN 55344
USA
Tel: 952-937-9800
Fax: 952-294-7722
www.hydraulics.eaton.com

Eaton
Hydraulics Operations Europe
Route de la Longeraie 7
1110 Morges
Switzerland
Tel: +41 (0) 21 811 4600
Fax: +41 (0) 21 811 4601

Eaton
Hydraulics Operations Asia Pacific
11th Floor Hong Kong New World Tower
300 Huaihai Zhong Road
Shanghai 200021
China
Tel: 86-21-6387-9988
Fax: 86-21-6335-3912

